

APPLICATION: 3 Axle 2S2M SIDE BY SIDE WABCO ABS

PART #: PAK2S2MS-3-W1

- CONTENTS:** Glad hand assemblies
 Air tank with installed drain valve and plugged unused ports
 Air tank mounting kit with pads, bolts, washers and lock nuts
 Brake valve(s) are installed and include push to connect fittings
 Hoses with swivel hose ends are installed to valve(s)
 Two speed sensors, sensor bushings and sensor extensions
 WABCO ABS power cord
 Hose separators and sensor cable retainers

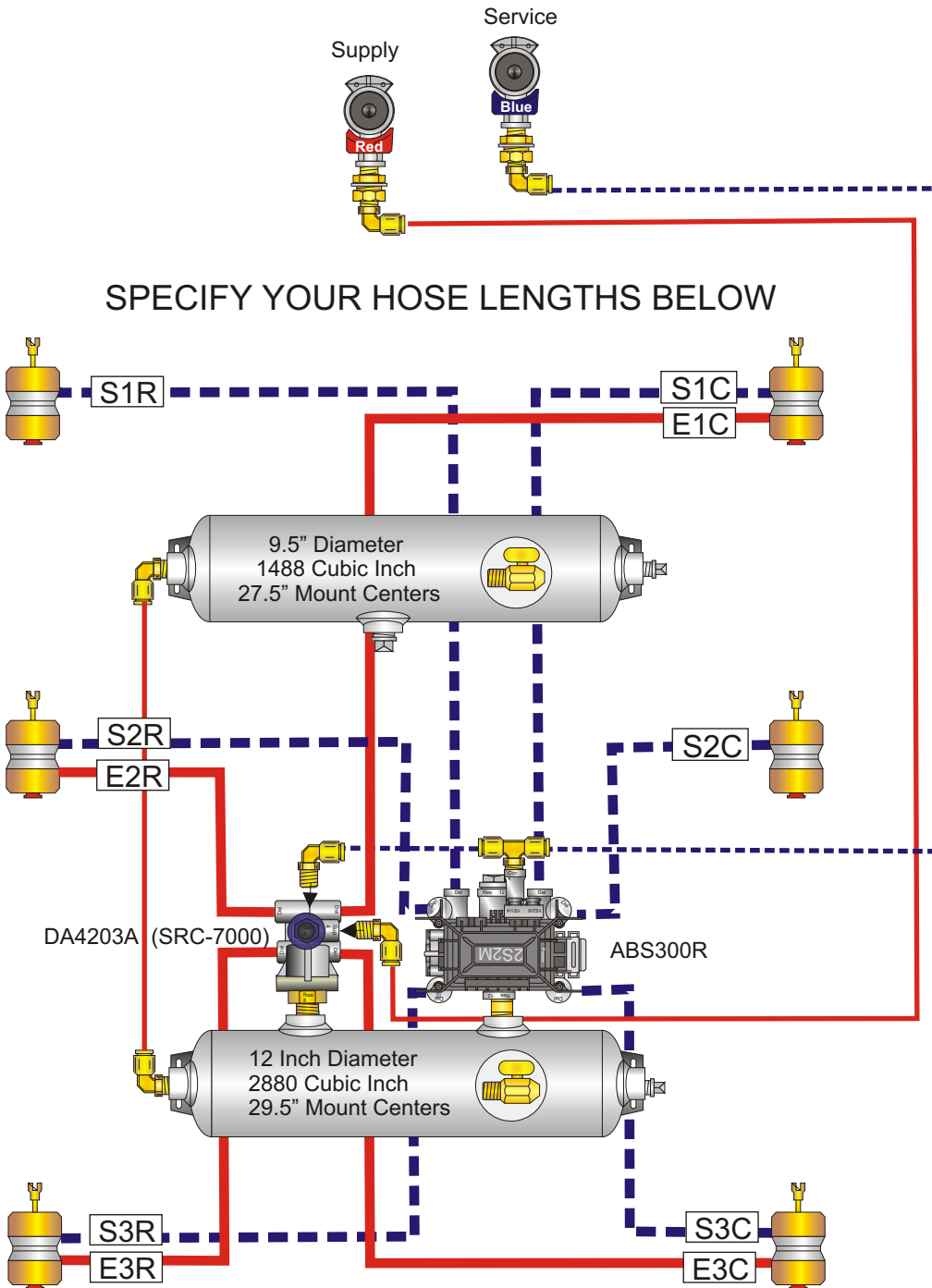

SPECIFY YOUR HOSE LENGTHS BELOW

OPTIONAL SYSTEMS

PAK2S2MS-3-W5
 SEALCO SPRING BRAKE VALVE

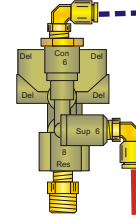

DA4201 (110500) SB PRIORITY

PAK2S2MS-3-W7
 SEALCO SPRING BRAKE VALVE

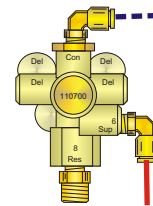

DA4201A (110700) SVC PRIORITY

PAK2S2MS-3-W8
 SEALCO SPRING BRAKE VALVE

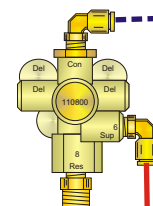

DA4201B (110800) SB PRIORITY

SUPPLIED WITH TWO SPRING BRAKE CROSSOVER KITS

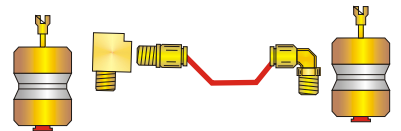

SPECIFY HOSE LENGTH IN INCHES EMERGENCY:

E1R	E1C
E2R	E2C
E3R	E3C

SERVICE:

S1R	S1C
S2R	S2C
S3R	S3C
S4R	S4C

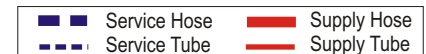

Specifications:

Hoses meet J1402 & JT106 specifications and are 3/8 ID unless otherwise noted. Reservoirs meet J10B specifications
 Pipe fittings are brass or plated SH80 steel. Push-in style 3/8 tube fittings standard. ABS Electronics pre-tested before shipment.